

BONALDO

Cross Table, Cross Table Glass

Designer: Alain Gilles



The top of the Cross Table rests only on a thin structure, but it is the wooden base in the shape of a cross that gives the table its solidity and structural force. The design of the modern wood table offers a collective vision in which the role of each element emerges in relation to the others in an appealing contrast between straight lines and soft curves, between masculinity and femininity. The three different and distinct elements that compose it offer the possibility of creating various combinations of finishes and colours, from the most original to the most understated, thereby creating a highly customisable accessory. The top is available in wood, ceramic or marble while a wide range of variants is also available for the finishes of the base, including elegant bronze, lead and pearl gold shades. It is also possible to choose from among three different wood variants for the lower cross. In the Cross Table Glass version, the central base is in transparent glass.

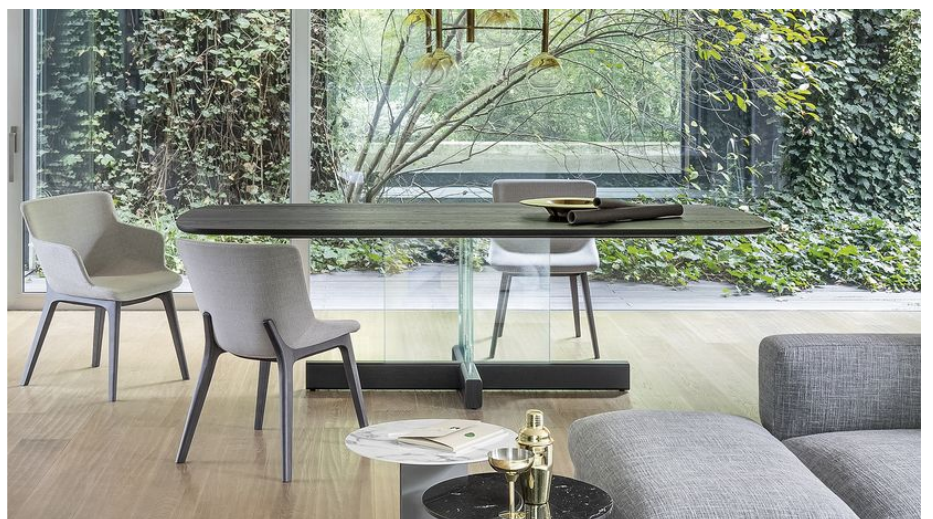

Data sheet

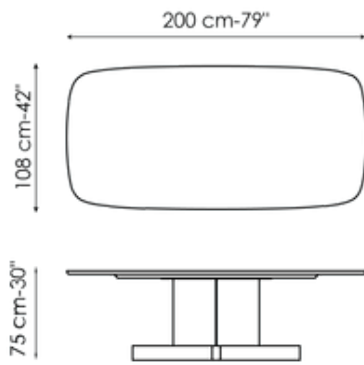

Width: 200cm
Depth: 108cm
Height: ± 75cm

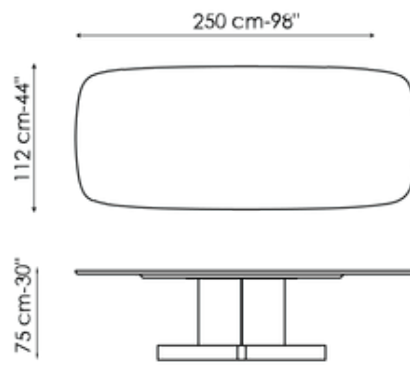

Width: 250cm
Depth: 112cm
Height: ± 75cm

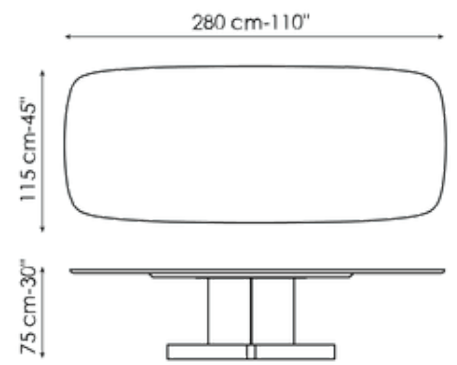

Width: 280cm
Depth: 115cm
Height: ± 75cm

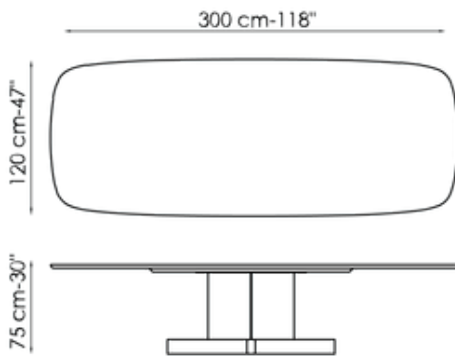

Width: 300cm
Depth: 120cm
Height: ± 75cm

Finishes

Top - Cross Table

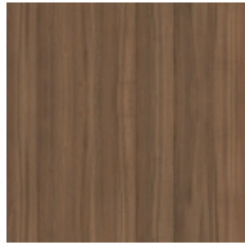

Veneered wood
Walnut Canaletto



Solid wood
Brushed coal oak

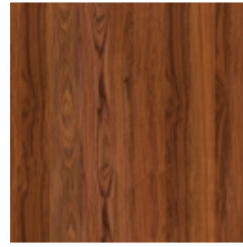

Solid wood
American walnut



Solid wood
Brushed natural oak



Glossy ceramic
Calacatta

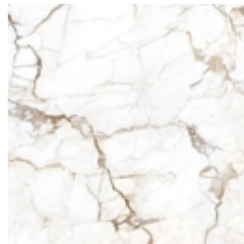

Silk finish ceramic
Calacatta macchia vecchia



Mat ceramic
Ardesia grey

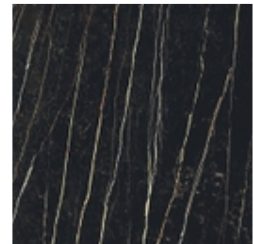

Mat ceramic
Laurent

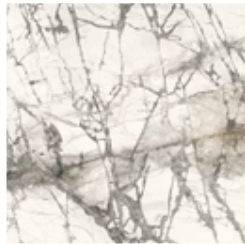

Glossy ceramic
Imperial grey

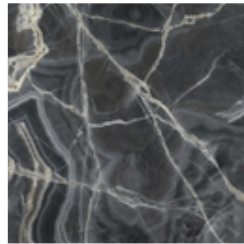

Glossy ceramic
Black Onyx

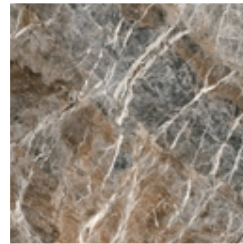

Glossy ceramic
Mountain peak

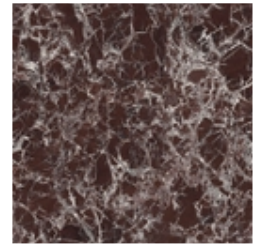

Glossy ceramic
Rosso imperiale

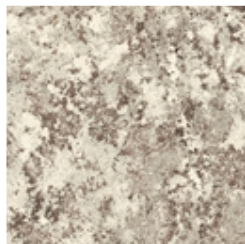

Mat ceramic
Alaska White



Mat ceramic
Augusta

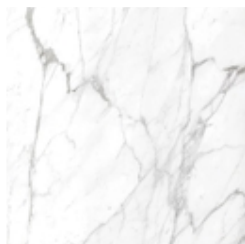

Marble
Calacatta

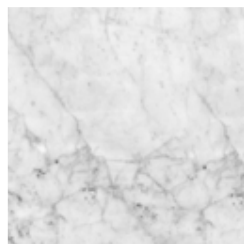

Marble
Carrara

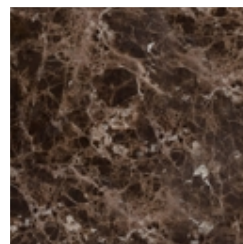

Marble
Emperador

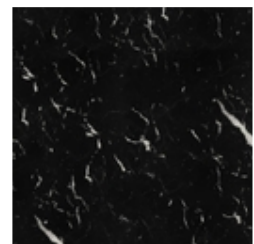

Marble
Marquinia

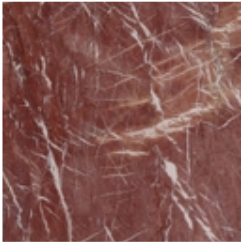

Marble
Rosso Carpazi

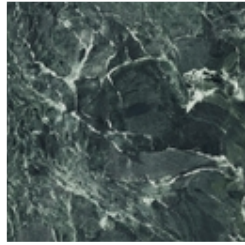

Marble
Saint Denis



Marble
Fior di bosco



Marble
Travertino Romano

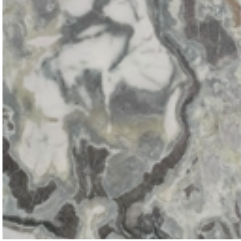

Marble
Dover White

Top - Cross Table Glass

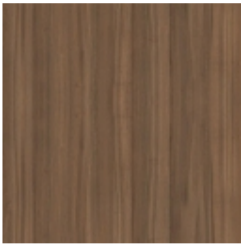

Veneered wood
Walnut Canaletto

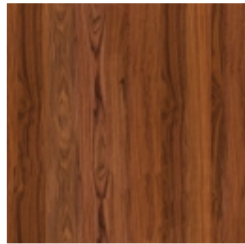

Solid wood
American walnut



Solid wood
Brushed coal oak



Solid wood
Brushed natural oak

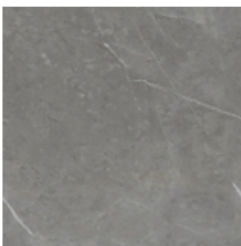

Mat ceramic
Ardesia grey

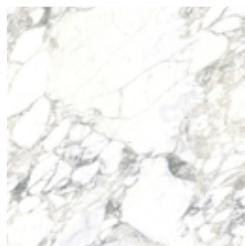

Glossy ceramic
Calacatta



Silk finish ceramic
Calacatta macchia vecchia

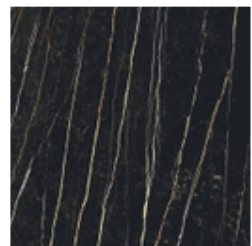

Mat ceramic
Laurent

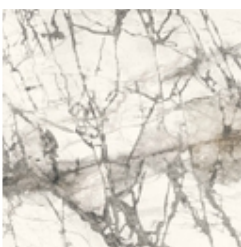

Glossy ceramic
Imperial grey

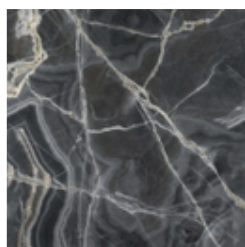

Glossy ceramic
Black Onyx

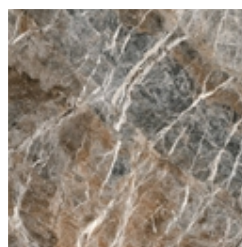

Glossy ceramic
Mountain peak

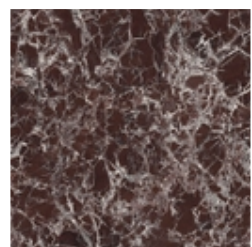

Glossy ceramic
Rosso imperiale

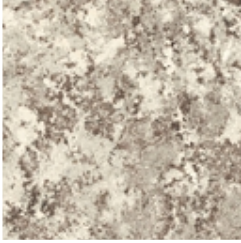

Mat ceramic
Alaska White



Mat ceramic
Augusta

Central base

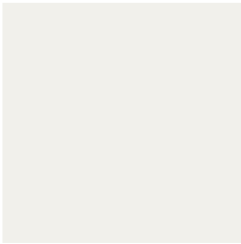

Painted metal
Mat white



Painted metal
Mat black



Painted metal
Mat brown



Painted metal
Mat dove grey



Painted metal
Mat pearl gold



Painted metal
Mat brass



Painted metal
Mat copper

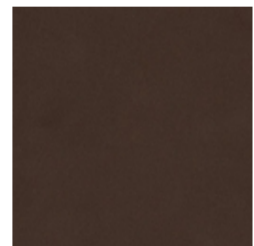

Painted metal
Mat bronze

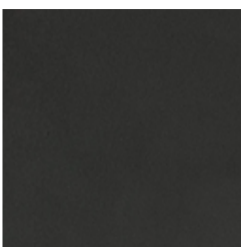

Painted metal
Mat lead

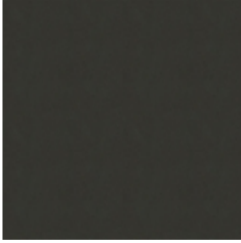

Metal finish
Burnished

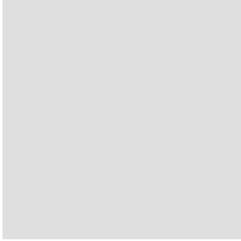

Glass
Transparent

Lower cross base

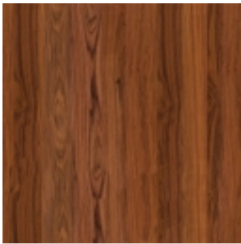

Solid wood
American walnut



Solid wood
Brushed coal oak



Solid wood
Brushed natural oak

Materials, fabrics, leathers, colors and finishes are approximate and may slightly differ from actual ones. You can find the complete collection of Bonaldo fabrics and leathers on the website <https://bonaldo.biz>